

POLYGON™

Miter and butt fusion for 63mm to 160mm (2"-6") polypropylene pipe
Socket fusion capability for 63mm to 125mm (2"-4") polypropylene pipe and fittings

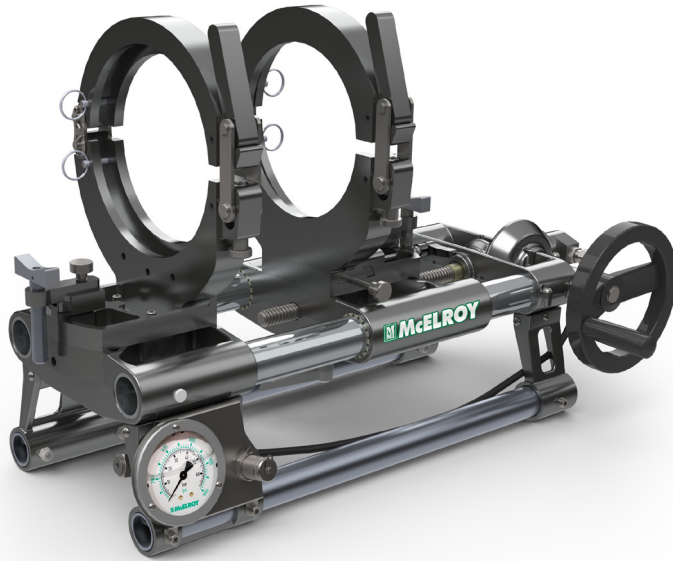

OVERVIEW

The **Polygon** is a multifaceted machine used to fabricate miter and butt fusion joints from zero- to 45-degree angles with additional socket fusion capability for polypropylene pipe. The mitering options are designed to meet the unique complexities of mechanical piping installations and retrofits, saving time and costs on purchasing molded or fabricated fittings.

The Polygon is McElroy's first manual butt fusion machine that is compatible with the DataLogger®, providing documentation that joints were fused according to standard. With its lightweight and simple design, it is perfect for tie-in fusions in confined spaces and fusing overhead. The Polygon easily adapts to socket fusion by swapping out the jaws with an optional Spider™ 125 Series 2 Adapter Kit. A stable base makes this versatile machine ideal for prefabrication and benchtop use.

FEATURES

- Produces miter, butt and socket fusion joints
- Quick clamp, pivoting jaws for faster, easier setup
- Adjustable, pivoting pipe supports to keep pipe level in the jaws
- Quick open/close, non-back-drivable wheel drive for smooth jaw movement
- Side-positioned wheel drive for easier movement of the carriage
- Power required only for the heater; battery-operated drill powers the facer
- First manual butt fusion machine with DataLogger capability
- Sturdy travel case for easy transport of entire machine and accessories
- Easy-to-view pressure gauge
- Uses the same inserts as the Acrobat™ 160

SPECIFICATIONS

CAPACITY

Fuses Pipe Sizes: 63mm - 160mm (2" - 6")

MODEL

A730001: 120V machine package

A730002: 240V machine package

A730005: 120V machine package and Spider 125 Series 2 Jaw Adapter Kit

POWER

Heater Power: 1,200 Watt

HYDRAULICS

Maximum Gauge Pressure: 400 PSI

WEIGHT

Machine: 42.1 lbs. (19.1 Kg)

Heater: 14.8 lbs. (6.7 Kg)

Facer: 16.4 lbs. (7.5 Kg)

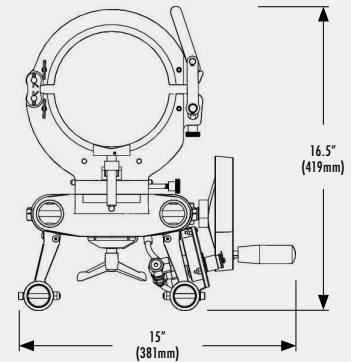
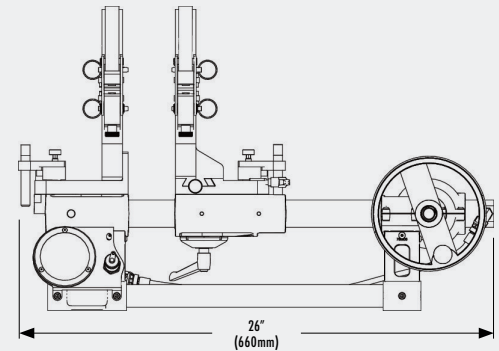

POLYGON

INCLUSIONS

Package includes Polygon fusion machine, 125mm inserts, heater, facer with drill motor, spare battery and charger, heater/facer stand and shipping case. Specifications subject to change without notice.